



UPUTSTVO ZA KORIŠĆENJE I ODRŽAVANJE STOLARIJE



suncemarinkovic.com



Poštovani,

Hvala vam na ukazanom poverenju i čestitamo na izboru energetske efikasne stolarije koja je usklađena sa evropskim i domaćim smernicama za kvalitet. Ovom kupovinom smo napravili zajednički korak u očuvanju planete i smanjenju emisije CO₂. U narednom kratkom uputstvu ćemo Vam prikazati nekoliko koraka u održavanju stolarije, kojih se treba pridržavati kako biste što duže uživali u SUNCE prozorima i vratima. Negujte i održavajte Vaše prozore redovno.

Molimo Vas da pre korišćenja stolarije, pročitate narednih nekoliko stranica.



PRE POČETKA RADOVA TREBA VIZUELNO PREKONTROLISATI VAŠE PROZORE I VRATA I TO:

- Količine;
- Ima li površinskih oštećenja?
- Da li je staklo polomljeno? Ukoliko postoji neusaglašenost u odnosu na količine, kvalitet prozora i vrata, molimo Vas da nas (ili našeg dilera) odmah obavestite.

TOKOM RADOVA TREBA OBRTITI PAŽNJU DA:

- Prozori i vrata budu obloženi folijom kako bi se zaštitili od oštećenja. Folija se uklanja nakon završetka svih radova na objektu, najkasnije mesec dana nakon ugradnje prozora.
- Malter, šut i prašina ne smeju da dođu u dodir sa okovom i gumom. U suprotnom, SUNCE Marinković ne garantuje za funkcionalnost prozora.
- Stolarija se održava isključivo sredstvima koje je propisao proizvođač (navedeno na stranama 5 i 6).
- Materijal koji se najviše koristi tokom građevinskih radova je voda. Velika količina vlage se na taj način unosi u objekat, zbog čega se prostorije moraju često provetravati. Između grejnog tela i stakla mora da postoji minimum 30 cm rastojanja. Ovo rastojanje obezbeđuje da staklo ne puca i sprečava pojavu kondenzata na staklu.
- Velika izloženost stakla visokim temperaturama spolja, uz prisustvo hladnijeg vazduha (od klima uređaja tokom leta) može da izazove pucanje stakala.

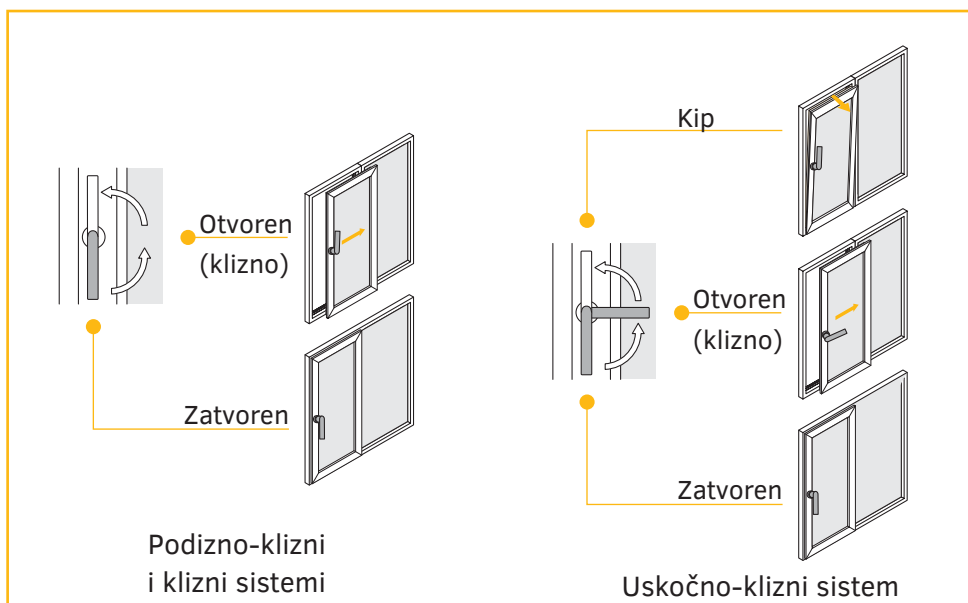
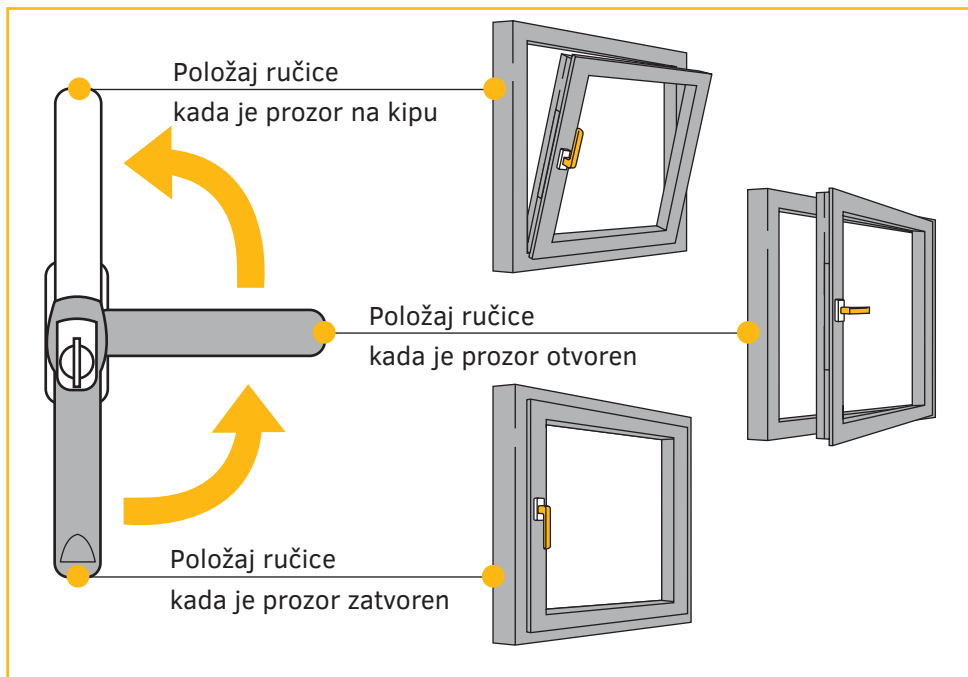



RUKOVANJE ROLETNAMA

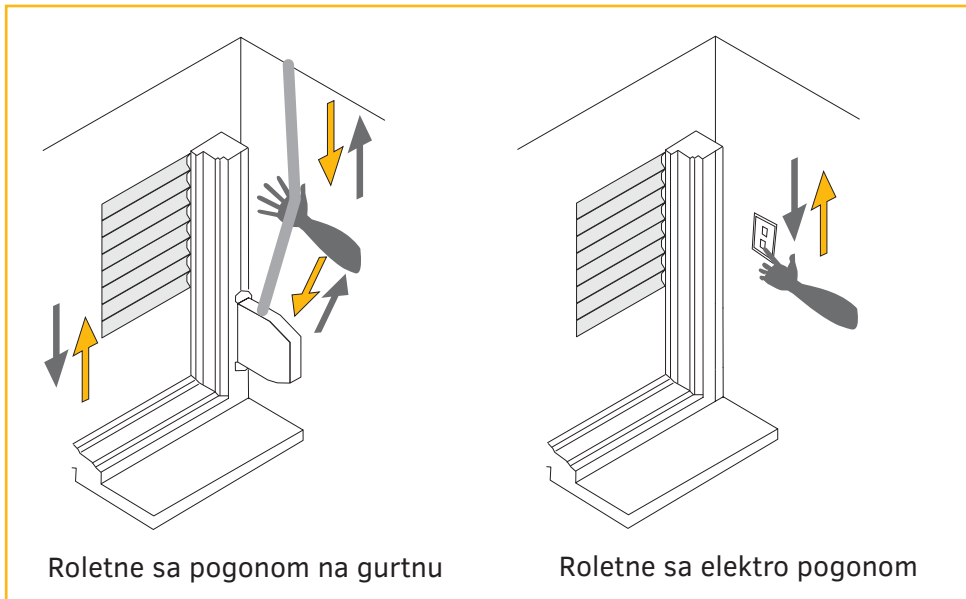

RUKOVANJE KOMARNICIMA

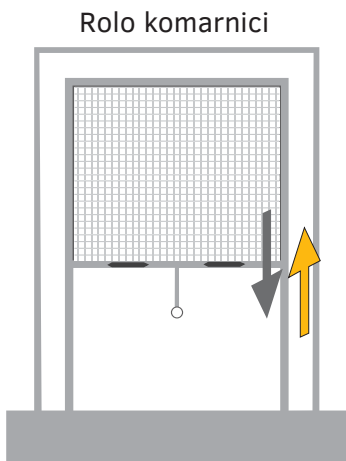

Komarnik spustiti do kraja, privući sebi i zakačiti za stopere sa leve i desne strane

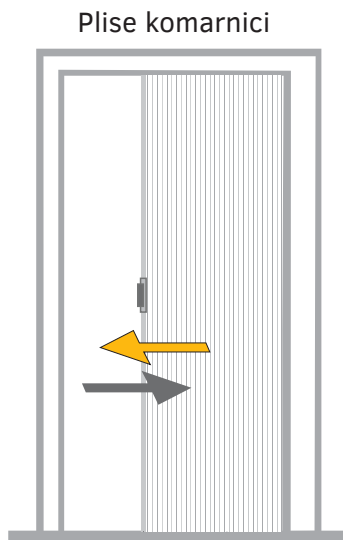

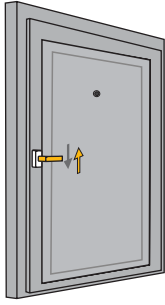

Zatvorena vrata

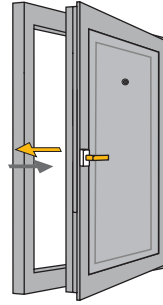

Otvorena vrata

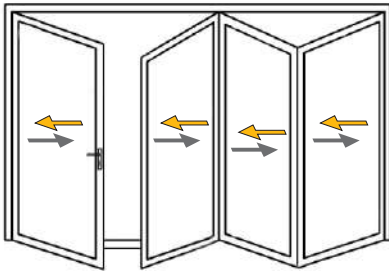

Harmonika sa parnim brojem krila

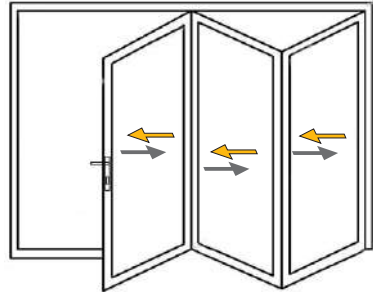

Harmonika sa neparnim brojem krila



ODRŽAVANJE STOLARIJE (profili, staklo, gume, okov...)

Stolarija se održava prema uputstvu proizvođača bez korišćenja agresivnih sredstava. Sledeće predmete nikako ne smete koristiti za održavanje prozora: oštri predmeti poput noža, sekire, zidarske špaklice, žičane sunđere, hrapaviju stranu sunđera za posuđe, agresivne hemikalije poput nitro razređivača, acetona, laka za nokte...

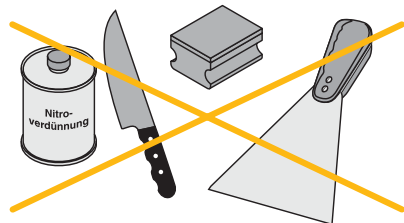



ODRŽAVANJE PROZORA

Zaštitnu foliju sa profila prozora treba ukloniti nakon montaže i obrade ivica, a najkasnije nakon mesec dana u zavisnosti od vremenskih uslova. Nečistoća izazvana prašinom ili kišom uklanja se jednostavno, uobičajenim sredstvima za pranje i mekom krpom. Staklo se čisti pomoću čiste, tople vode i krpe za staklo. Optimalnu negu prozora ćete ostvariti ako redovno održavate profile i dihtunge. Gips, malter i sličnu prljavštinu možete ukloniti drvenom i plastičnom špaklicom. Fleke možete ukloniti sredstvom za čišćenje profila. Drenažne rupe za odvod vode treba održavati tako da se iz njih otkloni sva prašina i predmeti koji mogu da zadržavaju prolaz vode. Prašina se može ukloniti usisivačem. Nanesite sredstvo za podmazivanje na dihtunge prozora. Dihtunzi se moraju održavati tako da ne budu suvi i „ispošćeni“.

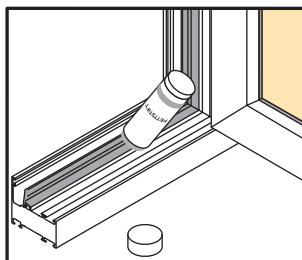
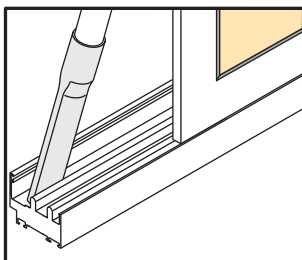

ODRŽAVANJE BRAVE VRATA

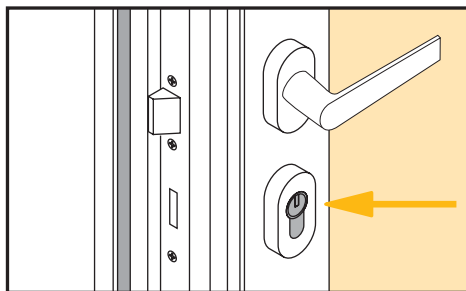
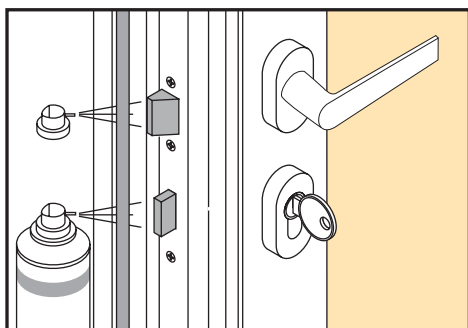

Bravu vrata i cilindar treba podmazati povremeno ili po potrebi

VAŽNO: MONTAŽA

Kupac je u obavezi da angažuje kompetentnog izvođača radova koji će montirati stolariju, ukoliko se prilikom potpisivanja ugovora opredelio da samostalno organizuje montažu. Za greške u montaži, ukoliko je kupac sam organizovao ugradnju stolarije, SUNCE Marinković ne preuzima odgovornost.



Sredstva za čišćenje stakala mogu da prouzrokuju pojavu žutila na profilima. Prilikom nanošenja sredstva i brisanja stakala, obratiti pažnju da sredstvo ne dođe u dodir sa profilima.

Savetuje se da se prilikom čišćenja stakala koristi što više vode, sa vrlo malim primesama sredstava za čišćenje.

Set za održavanje stolarije sadrži:

- mleko za čišćenje profila,
- sredstvo za podmazivanje guma,
- ulje za okove i
- krpu za čišćenje.



KONDENZACIJA



S obzirom da PVC i aluminijumska stolarija idealno dihtuje, potrebno je da provetrate povremeno svoj dom kako bi omogućili da se akumulirana vlaga u domu izluftira što će dugoročno sprečiti pojavu kondenzacije. Vlažnost u domu može nastati na različite načine, a među najvažnijima su vodena para iz domaćinstva (održavanje higijene i telesna isparenja ljudi), voda koja se javlja u tzv. vlažnim prostorijama, na pr. kupatilima, kuhinjama itd. ili voda za čišćenje, zalivanje i voda iz oštećenih cevi. Ukoliko je vlaga konstantna i visoka, znajte da će sigurno doći i do pojave buđavih čoškova. U slučaju bilo kakvih građevinskih radova u kući (krečenje, gletovanje, obrada špaletni...) obavezno treba omogućiti isušivanje zidova kako bi se vlaga eliminisala. Najbolji lek za kondenzaciju je provetranje. Provetravajte svoj dom par puta dnevno, posebno u toku zimskog perioda kada je pojava kondenzacije najčešća. Kratko provetranje pomoću promaje se pokazalo najboljim. Brzo provetranje štedi grejnu energiju, pri čemu je količina izmenjenog vazduha ista kao i kod trajnog provetranja.

SERVIS & REKLAMACIJE



Ukoliko je potrebno da se vaša stolarija našteluje, imate reklamaciju ili želite da nam pošaljete vaš komentar, možete nam se obratiti na telefon 034/617-0111. Operateru možete ostaviti vaše podatke i opis reklamacije. Zahtevi kupaca rešavaju u najkraćem roku, tako da će naš servisni tim odmah po prijemu reklamacije početi sa njenim rešavanjem. Svoje reklamacije ili primedbe možete poslati i preko web sajta suncemarinkovic.com Skenirajte QR kod za stranicu namenjenu prijemu reklamacija.





PODMAZIVANJE PROZORA





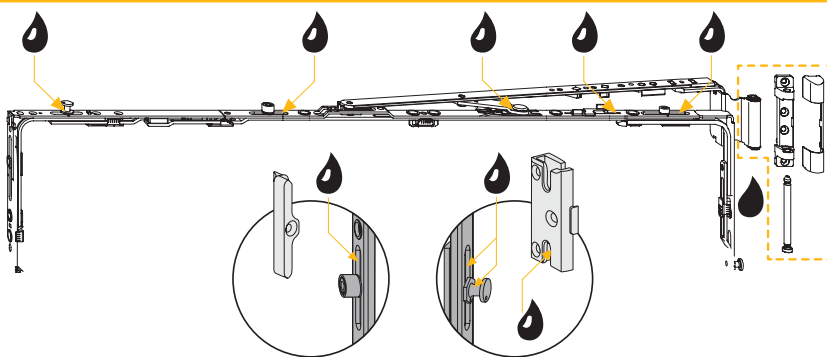
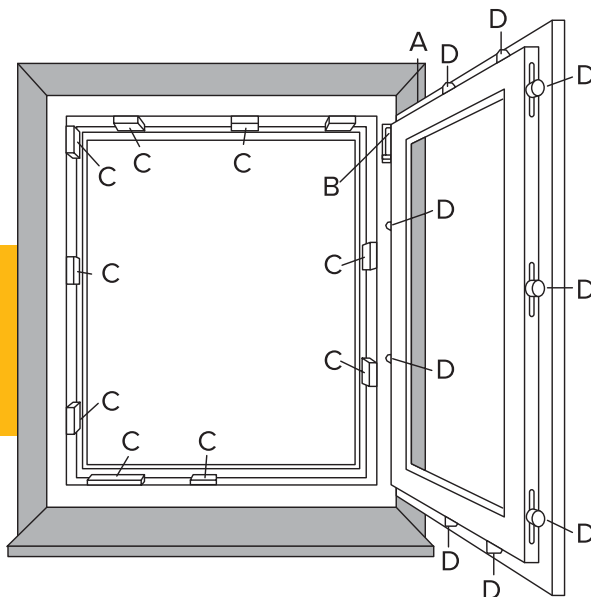

Vaši prozori i vrata su okovani kvalitetnim okovom koji se mora održavati kako bi se omogućilo njegovo nesmetano funkcionisanje. Okov se mora minimalno jednom godišnje podmazivati sredstvom koje preporučuje proizvođač. Pokretne delove okova (makaze, pogonski mehanizam, šnaper...) treba minimum jednom godišnje podmazati. Prilikom krećenja farba ne sme doći u dodir sa okovom.

A, C, D - funkcionalne tačke za podmazivanje.
B - sigurnosne tačke za podmazivanje.

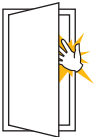

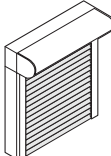
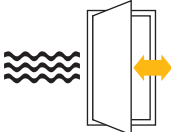
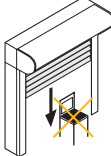
Institut za prozorsku tehniku IFT Rosenheim daje preporuku za održavanje stolarije i to: Poslovni objekti - jednom u 6 meseci. Škole, bolnice i drugi javni objekti - jednom u 6 meseci. Privatne kuće i stanovi - jednom u 12 meseci prema potrebi IFT preporučuje i održavanje sledećih elemenata: PVC profili - jednom u 6 meseci AL profili - jednom u 12 meseci (eloksirani profili 1 u 6 meseci) staklo - jednom u 6 meseci gume - jednom u 6 meseci okov - jednom u 6 meseci.

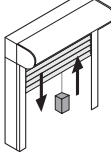
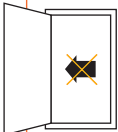
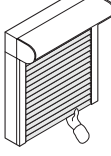
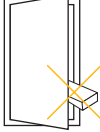
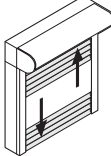

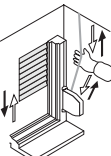
 <p>Mogućnost povrede priklještenjem između štoka i krila.</p>	 <p>U slučaju vremenskih nepriključa (oluja, jaki udari vetra, velike vrućine) držite roletne zatvorene. Prilikom pojave inja i slane na roletnama, sačekajte da se roletne otupe. Nakon toga ih možete normalno koristiti.</p> 
 <p>Mogućnost povrede u slučaju jakog vetra.</p>	 <p>Prilikom podizanja i spuštanja roletni lamele se moraju kretati bez prepreka. Ne postavljajte predmete ispod lamela.</p>
 <p>Pažnja! Krilo ne opterećivati dodatno.</p>	 <p>Roletne se ne smeju dodatno opterećivati drugim predmetima.</p>
 <p>Pažnja! Krilo ne naslanjati na zid zbog mogućnosti oštećenja malterom.</p>	 <p>Ne vucite lamele na gore kad je roletna spuštana. Tako možete pokvariti mehanizam.</p>
 <p>Pažnja! Ne postavljati predmete između štoka i krila.</p>	 <p>Ne otvarajte i ne pomerajte lamelice na roletnama na silu.</p>
 <p>Mogućnost ispadanja kroz prozor.</p>	 <p>Gurtna se uvek povlači vertikalno i uvek istom snagom, bez naglih pokreta koji mogu ugroziti funkcionalnost roletne.</p>

Pored redovnog čišćenja važno je da jednom godišnje ili po potrebi proverite dihtovanje prozora.

Usled izloženosti velikim razlikama u temperaturi i čestog korišćenja, može doći do potrebe da se PVC prozori i balkonska vrata našteluju kako bi se obezbedilo adekvatno dihtovanje. Dakle ukoliko Vaši PVC prozori propuštaju vazduh spolja sa strane, na vrhu ili dnu krila treba ih naštelovati. To je jednostavan posao koji možete i sami obaviti na lak način. Za ovaj posao vam je potreban imbus ključ broj 4 koji dobijate besplatno uz novu SUNCE stolariju.



Ukoliko je krilo spalo i ne dihtuje sa gornje strane, skinite plastičnu masku sa šarke u donjem delu prozora. Zatim postavite imbus ključ na vrh šarke u žljeb i okrenite u levu stranu. Ukoliko je krilo potrebno spustiti, odnosno ne dihtuje sa donje strane, imbus ključem okrenite šraf na desnu stranu.

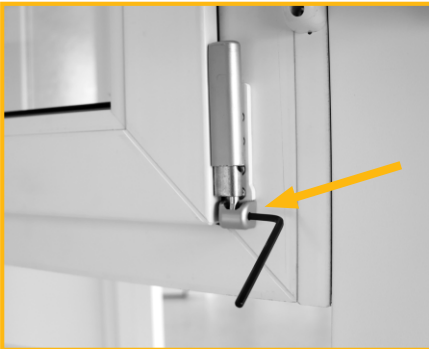

Ukoliko prozor ne dihtuje sa strane, skinite malu maskicu sa donje strane šarke u u dnu krila. Zatim imbus ključem okrećite ka unutra u smeru kazaljke na satu ili ka spolja u smeru suprotnom smeru od kretanja kazaljke na satu.

VAŠA EVIDENCIJA ODRŽAVANJA STOLARIJE ✨



When it comes to balcony PVC doors, adjustment is performed in the same way. In addition to the hinges located on the side of the wing, adjustment can be done on the upper part of the mechanism, right next to the upper hinge according to the same principle as for the lower hinges.

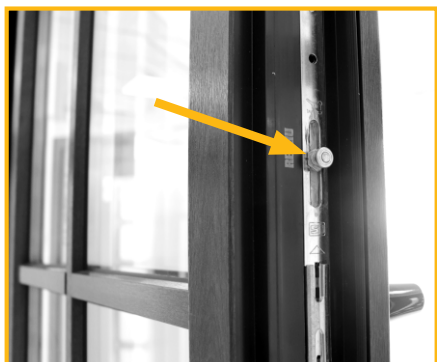

If the window does not seal or cannot be closed on the handle side, the screw which is placed on the side of the wing should be turned outward clockwise or inward counterclockwise.

ANKETA I ZADOVOLJSTVO KUPACA



Skenirajte QR i popunite online anketu o zadovoljstvu kupaca



Skenirajte QR kod i ostavite nam ocenu na Google-u

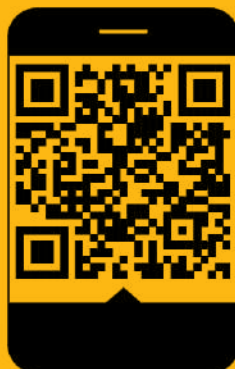



INSTRUCTIONS FOR USE AND MAINTENANCE OF DOORS AND WINDOWS



suncemarinkovic.com



Dear Valued Customer,

We appreciate your trust and commend your selection of energy-efficient carpentry, compliant with both European and national quality standards. Your choice aligns with environmental preservation and reduced CO2 emissions. This guide offers essential tips for maintaining your SUNCE doors and windows, ensuring their lasting performance.

Care and maintain your windows regularly.

Prior to carpentry usage, please review the following pages.



AT THE VERY BEGINNING YOU SHOULD CHECK:

- Quantity;
- Presence of surface damage or broken glass;

If there is any kind of disagreement, please inform us (or our dealer) immediately.

PAY ATTENTION TO THESE FEW GUIDELINES DURING INSTALLATION:

- Windows and doors should be covered with foil to prevent damage. It should be removed when all the work on the object is finished, no later than one month after window installation.

Mortar, rubble or dust must not come into contact with fitting or rubber. Otherwise, SUNCE Marinkovic will not guarantee the functionality of the windows.

- Carpentry is maintained exclusively with the products prescribed by the manufacturer (listed on the pages 5 and 6).

- During construction work, water is the most common used material. Thus, great amount of moisture enters the building, which is why rooms should be ventilated often. Minimum distance of 30cm must be provided between the heating element and the glass. The distance prevents glass breakage and condensation.

- Glass exposure to high temperatures from outside and cold air from inside (due to air conditioning during summer) can cause glass breakage.

CUSTOMER SATISFACTION

Scan the QR code and rate us on Google.

Thank you for your time.

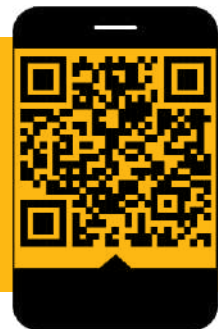

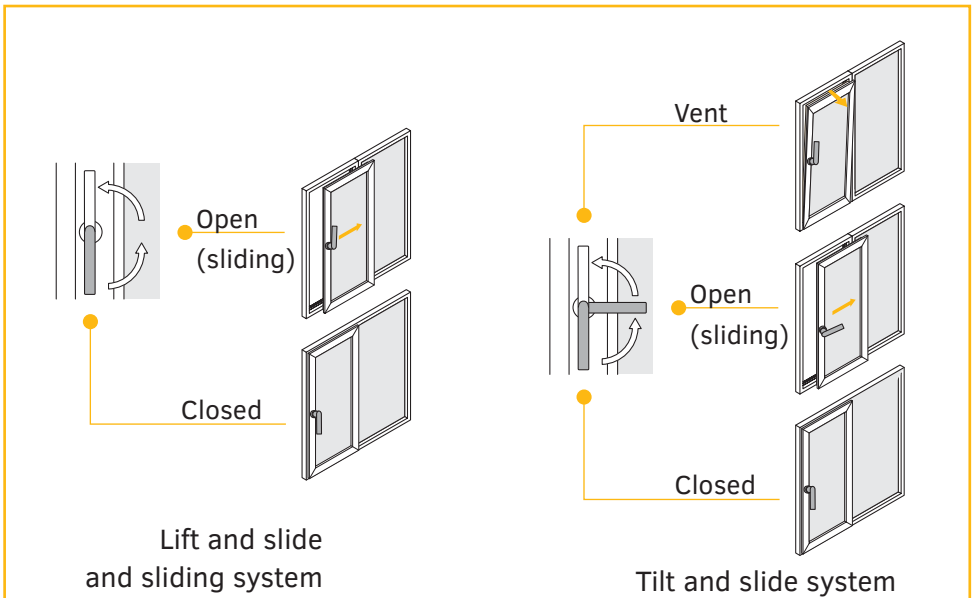
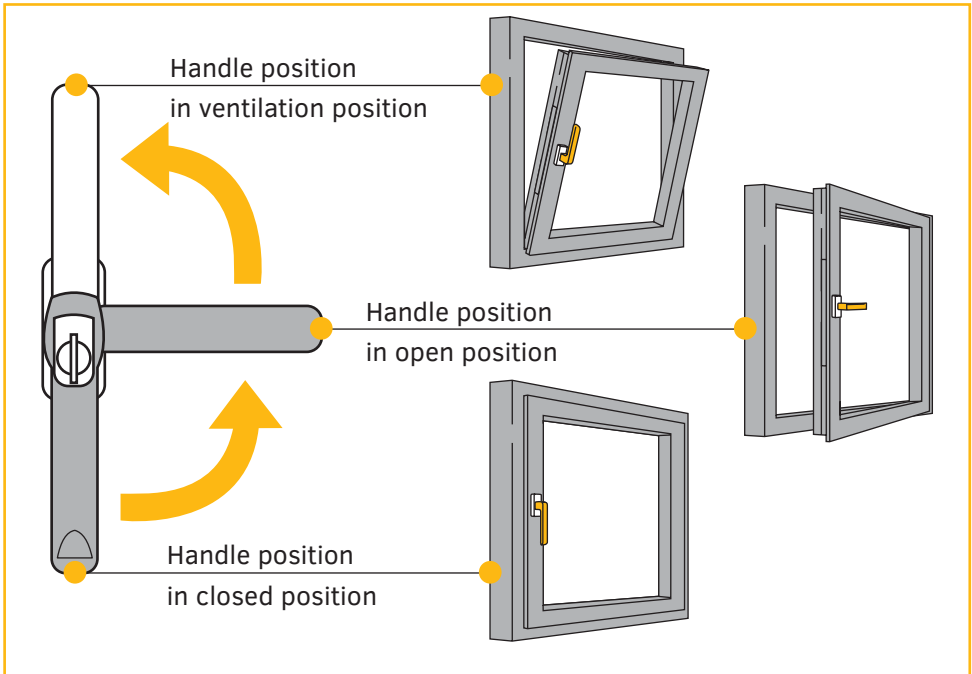



ROLLER BLINDS HANDLING

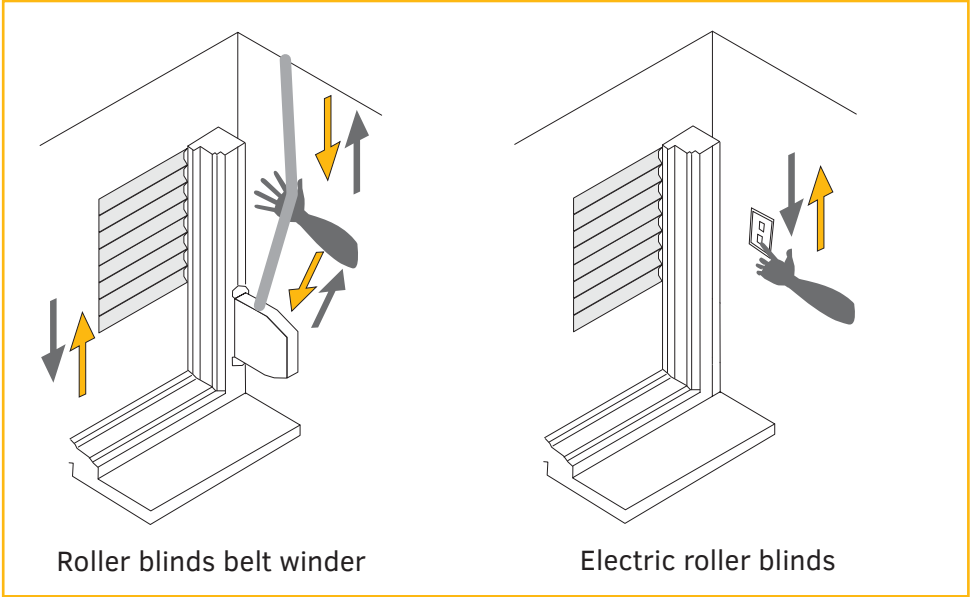

INSECT SCREEN HANDLING

Roller insect screen

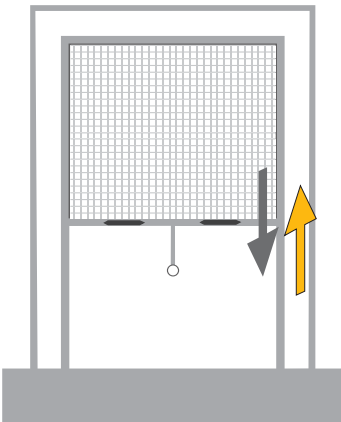

Lower the insect screen all the way and attach it to the stoppers on the left and right.

Plisse insect screens

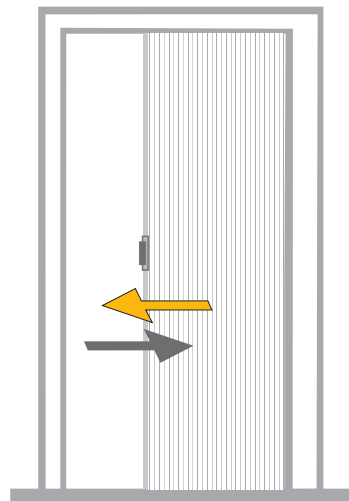

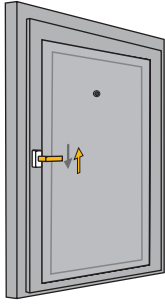

Closed door

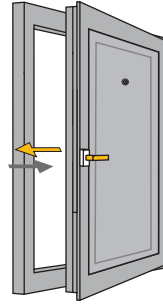

Opened door

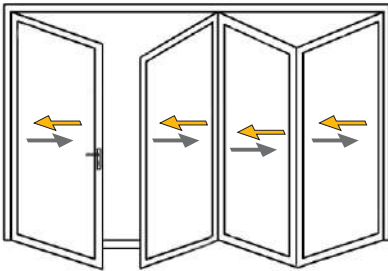
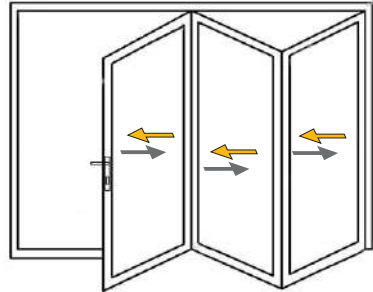
Even number wings
accordion doorOdd number wings
accordion door

CARPENTRY MAINTENANCE (profiles, glass, rubber, fittings...)

Carpentry is maintained according to the manufacturer`s instructions without using aggressive agents: sharp objects such as a knife, axe, metal spatula, wire sponges, the rougher side of a dish sponge, aggressive chemicals (nitro thinner, acetone, nail polish...)

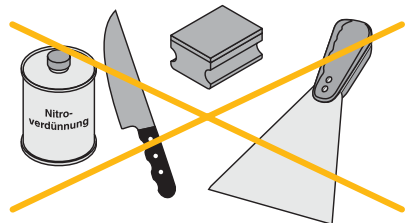



WINDOW MAINTENANCE

Protective foil should be removed after window installation and jamb extension installation, no later than a month after installation depending on weather conditions. Dirt caused by dust or rain can be easily removed with a detergent and soft cloth. The glass is cleaned using clean, warm water and a glass cloth. You will achieve optimal window care if you regularly maintain profiles and gaskets. Plaster, mortar and similar dirt can be removed with plastic or wooden spatula. Stains can be removed with profile cleaner. Drainage holes should be maintained so that all dust and objects that can block the passage of water are removed from them. Dust can be removed with a vacuum cleaner. Apply a lubricant to the window gaskets. Gaskets must be maintained so that they are not dry or worn out.

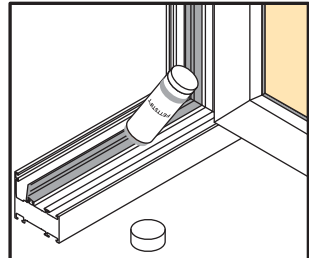
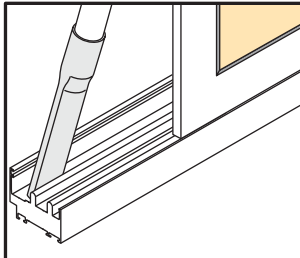

DOOR LOCK MAINTENANCE

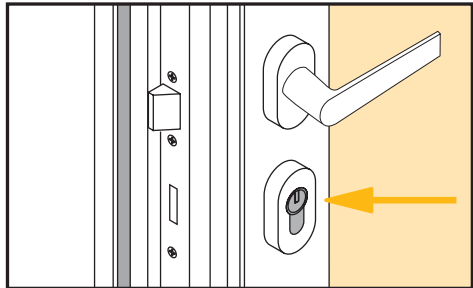
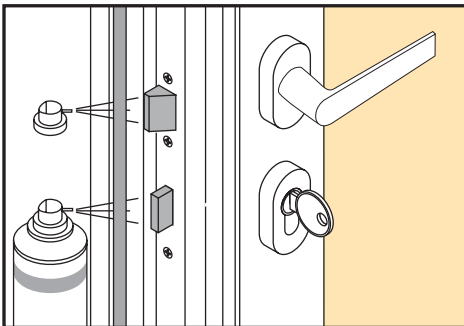

Door lock and cylinder should be lubricated occasionally or as needed

IMPORTANT: INSTALLATION

The buyer is obliged to hire a competent contractor for carpentry installation, if he decides to organize installation independently. In that case, SUNCE Marinkovic assumes no responsibility for any irregularities due to an improper installation.



Glass cleaners can cause yellowing of the profiles. When applying the agent and wiping the glass, pay attention that it does not come into contact with the profiles. When cleaning the glass, it is recommended to use as much water as possible, with very little admixture of cleaning agents.

Carpentry maintenance set contains:

- profile cleaning milk,
- rubber lubricant,
- hardware oil and
- cleaning cloth.



CONDENSATION



Given that PVC and aluminum joinery ideally seals, you need to ventilate your home occasionally to allow the accumulated moisture in the home to air out, which will prevent condensation in the long run. Humidity in the home can occur in different ways, and among the most important are water vapor from the household (maintenance of the hygiene and bodily vapors of people), water that appears in the so-called wet rooms, e.g. bathrooms, kitchens, etc. or water for cleaning, watering and water from damaged pipes. If the humidity is high and constant, know that moldy corners will certainly appear. When it comes to any construction work in the house (plastering, painting the walls, jamb extension installation, etc.), it is necessary to enable drying of the walls in order to eliminate moisture. The best remedy for condensation is ventilation. Ventilate your home several times a day, especially during the winter when condensation is most common. Brief airing with a draft proved to be the best since it saves heating energy.

CUSTOMER SERVICE AND COMPLAINTS



If you need your carpentry to be adjusted, if you have a complaint or you want to send us your comment, you can call us at 034/617-0111.

You can leave your data and our service team will resolve your requests shortly. You can also send your complaints and comments using suncemarinkovic.com web site. Scan the QR code which leads to a page for receiving complaints.





WINDOW LUBRICATION



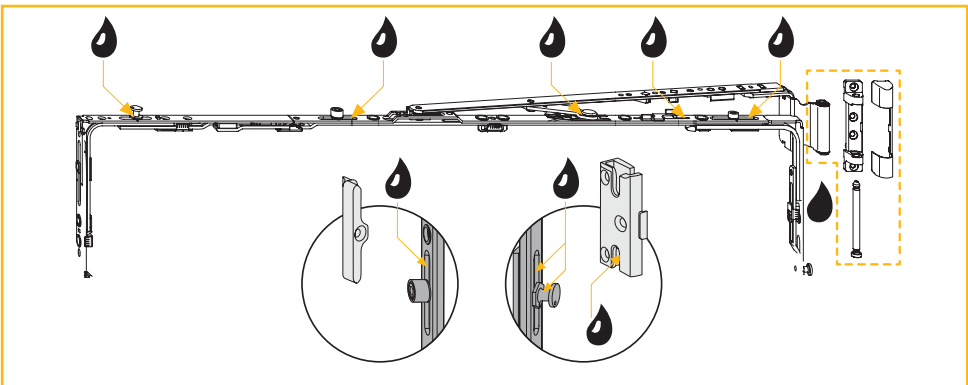
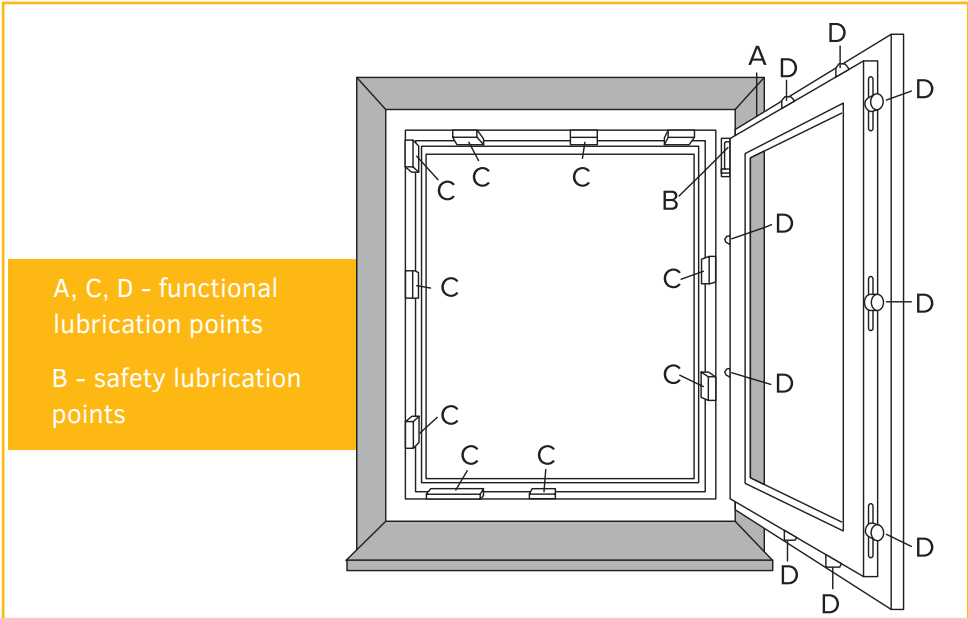



Your windows and doors are equipped with quality hardware that must be maintained in order to enable its smooth functioning. It must be lubricated at least once a year with a product recommended by the manufacturer. Movable parts of the hardware (scissors, mechanism, snapper...) should be lubricated at least once a year. When painting, the paint must not come into contact with the fittings

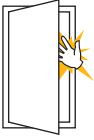

The IFT Rosenheim Institute for window technology recommends the maintenance of joinery, namely: office buildings, schools, hospitals and other public facilities – once every 6 months. Private houses and apartments – once a year or as needed. IFT also recommends maintenance of the following elements: PVC profiles – once every 6 months, AL profiles – once a year (anodized profiles once in 6 months), glass, rubber and hardware – once in 6 months.

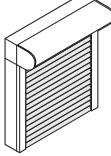
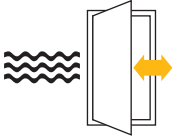
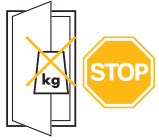
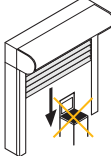
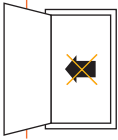
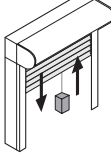
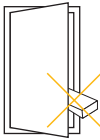
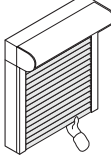

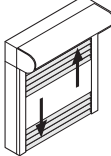
SAFETY PRECAUTIONS

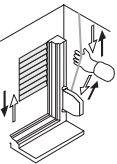
 <p>Possibility of injury by being pinched between wing and</p>	 <p>In case of bad weather (storms, strong gusts of wind, high temperatures) keep the blind down. If they appear on the blinds, wait for the frost and salt to melt, before using the blinds</p> 
 <p>Possibility of injury due to a strong wind</p>	
 <p>Attention! Do not put additional weight on the wing.</p>	 <p>When lifting and lowering the blinds, slats must move without any obstacles. Do not place objects under the slats.</p>
 <p>Attention! Do not lean the wing against the wall due to the possibility of damage by mortar.</p>	 <p>Do not put any additional weight on blinds.</p>
 <p>Attention! Do not place objects between wing and door frame.</p>	 <p>Do not pull the slats upwards when the blind is down. That way you can break the mechanism.</p>
 <p>The possibility of falling out of the window.</p>	 <p>Do not forcefully open or move the slats on the blinds.</p>
 <p>Mogućnost ispadanja predmeta kroz prozor, koji tako mogu povrediti prolaznike.</p>	 <p>Always retreat belt strap vertically and with same force, without sudden movements that can compromise functionality of the blinds.</p>



In addition to regular cleaning, it is important to check whether the window is sealed well. Due to exposure to fluctuating temperatures and frequent use, in order to provide windows to be adequately sealed, PVC windows and balcony doors should be adjusted occasionally. Therefore, if your PVC window let in air on the side, bottom or top of the wing window, they should be adjusted.

It is simple procedure that even you can perform on your own. All you need is Allen key number 4, which you get for free.



If the wing window has slipped and does not seal at the top, remove plastic mask from the hinge in the lower part of the window. Afterwards place the Allen key on top of the hinge in the pit and turn to the left. If the wing needs to be lowered, i.e. if it does not seal at the bottom, turn the screw to the right.



If the window does not seal on the side, remove the small mask from the lower side of the hinge at the bottom of the wing. Then turn the Allen key inward clockwise or outward counterclockwise.

ADJUSTING BALCONY DOORS



When it comes to balcony PVC doors, adjustment is performed in the same way. In addition to the hinges located on the side of the wing, adjustment can be done on the upper part of the mechanism, right next to the upper hinge according to the same principle as for the lower hinges.

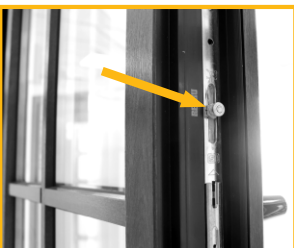

If the window does not seal or cannot be closed on the handle side, the screw which is placed on the side of the wing should be turned outward clockwise or inward counterclockwise.



**PFLEGE- UND
WARTUNGSANLEITUNG
FÜR SUNCE MARINKOVIĆ
FENSTER UND TÜREN**



suncemarinkovic.com



Sehr geehrte Damen und Herren,

wir möchten Ihnen herzlich zu Ihren neuen SUNCE Fenstern und Türen gratulieren und uns gleichzeitig für das entgegengebrachte Vertrauen bedanken. Ihre Entscheidung für unsere Produkte trägt nicht nur zur Verschönerung Ihres Zuhauses bei, sondern auch zu einer nachhaltigeren Zukunft. Durch die Verwendung von energieeffizienten Fenstern und Türen leisten Sie einen bedeutenden Beitrag zur Reduzierung von CO₂-Emissionen. Diese umweltfreundlichen Produkte sind darauf ausgelegt, den Energieverbrauch zu minimieren und dadurch den CO₂-Fußabdruck zu verringern.



Um sicherzustellen, dass Sie langanhaltende Freude an Ihren neuen Fenstern und Türen haben, haben wir eine umfassende Bedienungs-, Wartungs- und Instandhaltungsanleitung für Sie zusammengestellt. Ähnlich wie bei Ihrem Auto erfordern auch Ihre Fenster regelmäßige Pflege und Wartung. Wenn Sie die in der Anleitung empfohlenen Maßnahmen befolgen, werden Sie nicht nur von der Langlebigkeit Ihrer Fenster profitieren, sondern auch von den positiven Auswirkungen auf die Energieeffizienz Ihres Hauses.

Sie haben die Möglichkeit, diese Wartungsmaßnahmen entweder eigenständig durchzuführen oder sich für einen professionellen Wartungsauftrag durch unser Haus

AM ANFANG SOLLTEN SIE FOLGENDES ÜBERPRÜFEN:

- Die Anzahl der gelieferten Fenster und Türen.
- Das Vorhandensein von Oberflächenschäden oder zerbrochenem Glas. Falls Unstimmigkeiten festgestellt werden, informieren Sie uns (oder unseren Händler) bitte umgehend.



WICHTIGE HINWEISE ZUR INSTALLATION:

- Bitte beachten Sie die folgenden Richtlinien sorgfältig, um eine einwandfreie Installation zu gewährleisten:

Schutz vor Beschädigungen: Um Schäden zu vermeiden, empfehlen wir, Fenster und Türen mit einer Schutzfolie zu bedecken. Die Entfernung dieser Folie sollte erst erfolgen, wenn sämtliche Arbeiten am Gebäude abgeschlossen sind. Spätestens jedoch einen Monat nach dem Einbau der Fenster sollte die Folie entfernt werden.

Sorgfältiger Umgang mit Materialien: Achten Sie darauf, dass Mörtel, Bauschutt oder Staub nicht in Kontakt mit den Beschlägen oder Dichtungen der Fenster und Türen gelangen. Andernfalls können wir keine Garantie für die einwandfreie Funktion der Produkte übernehmen.

Pflege gemäß Herstellervorgaben: Die Pflege von Fenstern und Türen sollte ausschließlich mit den empfohlenen Pflegeprodukten des Herstellers (siehe Seiten 5 und 6) erfolgen.

Feuchtigkeitsregulierung während Bauarbeiten: Während der Bauphase wird häufig Wasser als Baumaterial verwendet, was zu erhöhter Feuchtigkeit im Gebäude führen kann. Regelmäßiges Lüften der Räume ist daher ratsam. Zwischen Heizelementen und Glas ist ein Mindestabstand von 30 cm einzuhalten, um Glasbruch und Kondensation zu vermeiden.

Temperaturschwankungen beachten: Aufgrund der starken Temperaturunterschiede zwischen Außenhitze und Innenkälte (insbesondere während der sommerlichen Klimatisierung) besteht die Möglichkeit von Glasbruch. Bitte beachten Sie diesen Aspekt.

Vielen Dank für Ihre Beachtung dieser Richtlinien. Diese Maßnahmen tragen dazu bei, dass Sie lange Freude an Ihren neuen Fenstern und Türen haben werden. Bei Fragen stehen wir Ihnen gerne zur Verfügung.

HANDHABUNG VON ROLLOS

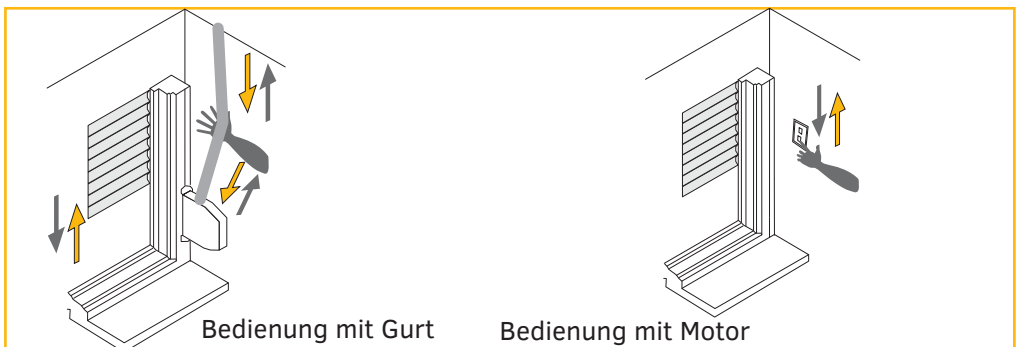



HANDHABUNG VON INSEKTENGITTERN

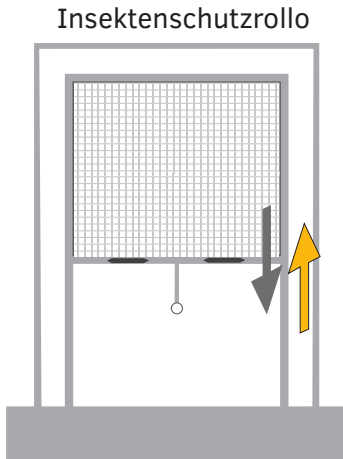

Insektenschutzrollo

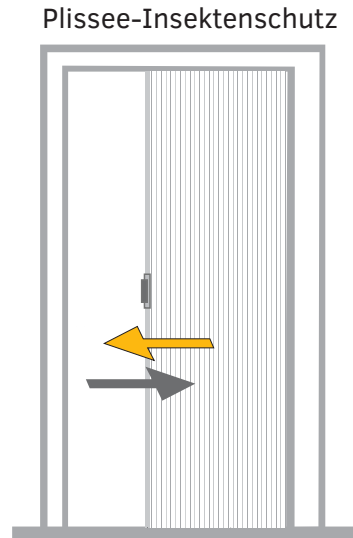

Plissee-Insektenschutz

Endstab des Insektenschutzgitters
gleichmäßig und langsam ziehen.
Endstab rastet automatisch ein.

Zum Herunterziehen die Zugschnur am Endstab zur Fenstermitte verschieben
oder Endstab direkt über Griffmulde mittig nach unten bewegen.



FENSTERHANDHABUNG

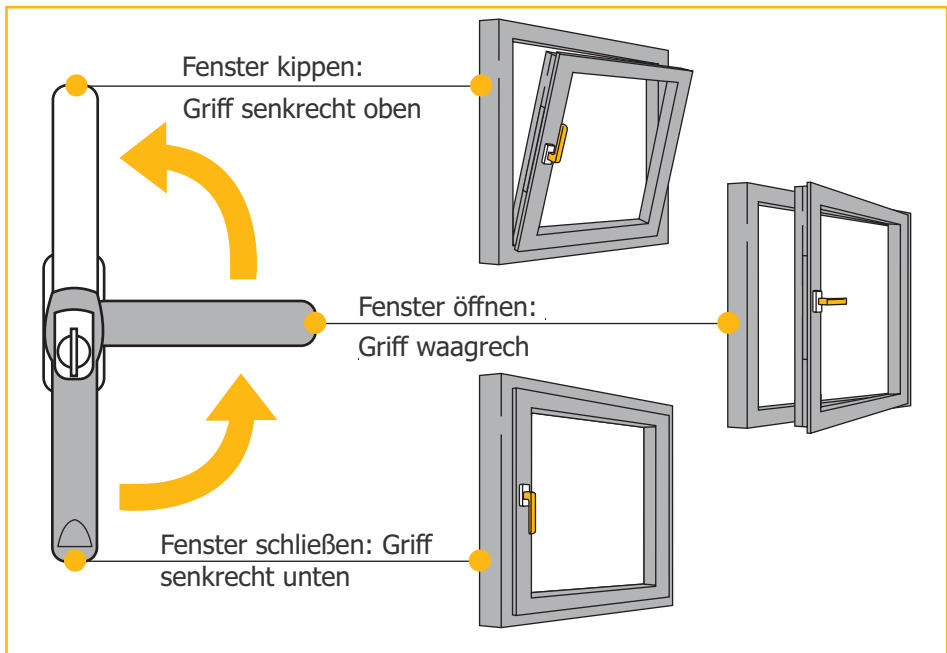

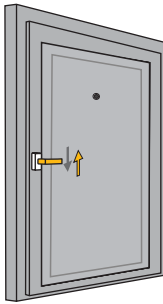
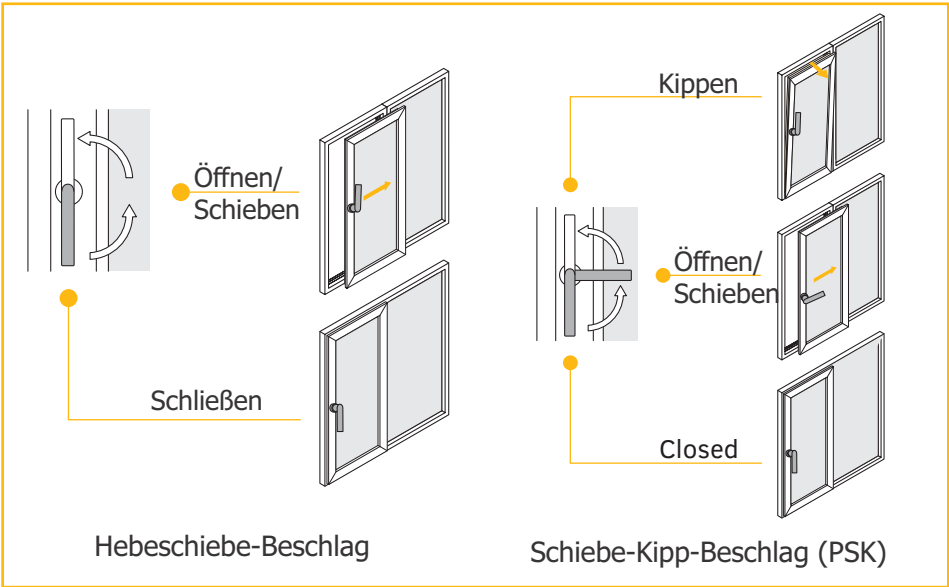

Geschlossene Tür

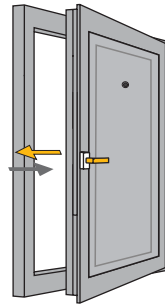

Geöffnete Tür

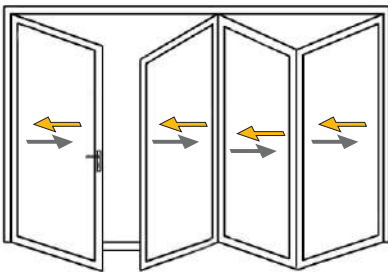

Akkordeontür mit gerader Flügelnummer

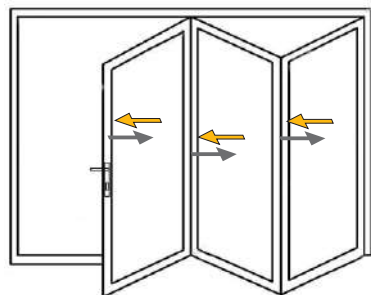

Akkordeontür mit ungerader Flügelnummer



WARTUNG DER FENSTER UND TÜREN (Profile, Glas, Dichtungen, Beschläge...)

Die Pflege der Fensterarbeiten sollte gemäß den Herstelleranweisungen erfolgen, unter Vermeidung des Einsatzes aggressiver Mittel. Bitte nutzen Sie keine scharfen Werkzeuge wie Messer, Äxte, Metallspachteln oder Drahtschwämme. Auch die grobe Seite von Schwämmen sowie aggressive Chemikalien wie Nitroverdünnung, Aceton oder Nagellackentferner sollten vermieden werden.



FENSTERPFLEGE



Die Schutzfolie sollte nach der Montage des Fensters und der Laibungsverlängerung entfernt werden, spätestens jedoch innerhalb eines Monats nach der Montage, je nach den Witterungsbedingungen. Verschmutzungen durch Staub oder Regen lassen sich mühelos mit einem Reinigungsmittel und einem weichen Tuch entfernen. Die Reinigung des Glases erfolgt am besten mit klarem, warmem Wasser und einem speziellen Glastuch. Um die Fenster optimal zu pflegen, empfiehlt es sich, Profile und Dichtungen regelmäßig zu behandeln. Verschmutzungen wie Putz oder Mörtel können vorsichtig mit einem Kunststoff- oder Holzspachtel entfernt werden. Flecken lassen sich mit einem Profilreiniger beseitigen. Die Abflusslöcher sollten offen gehalten werden, um das Entfernen von Staub und möglichen Blockaden zu ermöglichen – hier kann ein Staubsauger hilfreich sein. Tragen Sie ein passendes Gleitmittel auf die Fensterdichtungen auf, um ihre Lebensdauer zu verlängern. Dichtungen müssen regelmäßig gepflegt werden, um Austrocknung und Abnutzung zu verhindern.

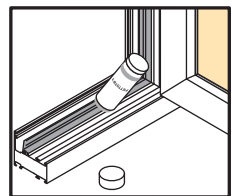
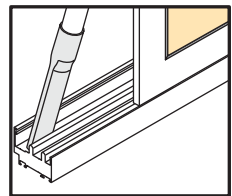



WARTUNG DES TÜRSCHLOSSES

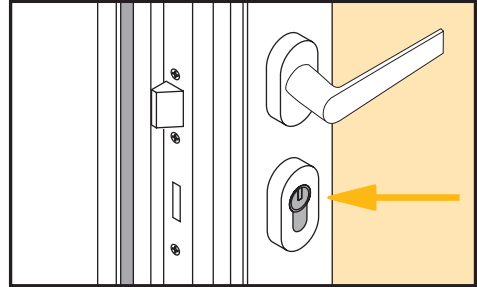
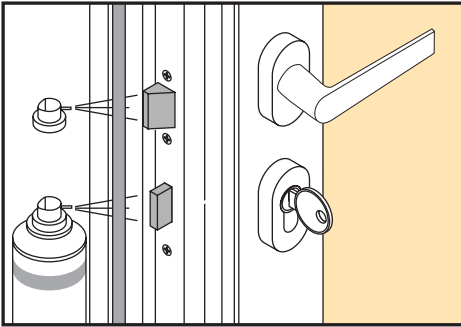

WICHTIGER MONTAGEHINWEIS

Es empfiehlt sich, das Türschloss und den Zylinder regelmäßig, je nach Bedarf, mit Öl zu schmieren.

Der Käufer sollte sorgfältig darauf achten, einen erfahrenen Fachmann für die Montage der Fenster und Türen zu beauftragen, wenn er sich dazu entschließt, die Montage eigenständig zu organisieren. In solchen Fällen übernimmt SUNCE Marinkovic keine Verantwortung für mögliche Mängel, die aufgrund einer unkompetenten Montage auftreten könnten.



WARTUNG VON TÜREN UND FENSTERN

Normal verschmutzte Fenster- und Türrahmen können leicht mit handwarmem Wasser, unter Zusatz eines Geschirrspülmittels, gereinigt werden. Reinigen Sie Glas am besten mit klarem, warmem Wasser mit Hilfe eines guten Fensterleders. Dabei können von den Dichtungen, falls Sie zu kräftig darüber reiben, schwarze Streifen auf das Leder übertragen werden. Wenn erforderlich, kann dem Wasser ein wenig Spülmittel zu- gesetzt werden. Verwenden Sie keine aggressiven oder lösungsmittelhaltigen Reiniger oder Scheuermittel. Eine trockene Reinigung mit einem Staubtuch o.ä. ist zu vermeiden.

Zur korrekten Pflege von Profilen und Beschlagsteilen benutzen Sie am besten ein spezi- elles Pflegeset, das Sie über Ihren Fensterfachhandel beziehen können (z. B. EasyCare von Schüco). Diese sind hautfreundlich und biologisch abbaubar, wirken antibakteriell und antistatisch. Damit pflegen Sie Ihre Fenster und schonen gleichzeitig die Umwelt.





Moderne PVC- und Aluminium -Fenster sind sowohl in sich als auch zum Baukörper hin so abgedichtet, dass kein natürlicher Luftaustausch stattfinden kann. Wer für den erforderlichen Luftaustausch sorgt, kann ein gesundes Raumklima erzielen und gleichzeitig Heizkosten sparen. Schnell und effektiv ist die Querlüftung gegenüberliegender zweier Fenster, da ein einziges offenes Fenster allein manchmal nicht ausreicht. 5 Minuten genügen bereits für einen Luftaustausch. Für die gründlichere Stoßlüftung braucht man etwa 10 Minuten.

Unsere Empfehlung:

- drei- bis viermal am Tag lüften
- Hindernisse für den Luftstrom entfernen: Möbel ein paar Zentimeter von der Wand aufstellen, Gardinen nicht direkt vor die Heizung hängen - sie sollten nur bis zur Fensterbank reichen
- Türen zu weniger beheizten Räumen geschlossen halten
- beim Auftreten von Feuchtigkeit durch Kochen, Baden, Duschen etc. häufiger lüften
- in kalten Jahreszeiten mehrmals täglich die Fenster kurzzeitig vollständig öffnen, statt sie stundenlang gekippt zu halten
- feuchte Raumluft immer nach außen ableiten - niemals in andere Räume
- ein beschlagenes Fenster ist ein deutliches Zeichen, dass gelüftet werden muss
- Heizen und regelmäßiges Lüften sind Voraussetzungen für ein gesundes Raumklima.

KUNDENSERVICE UND REKLAMATIONEN



Sollten Sie Änderungen an Ihren Fenstern und Türen vornehmen müssen, eine Reklamation haben oder uns Ihr Feedback zukommen lassen möchten, stehen wir Ihnen gerne zur Verfügung. Sie erreichen uns telefonisch unter +381 34 617-0111. Bitte hinterlassen Sie Ihre Kontaktdaten und beschreiben Sie kurz Ihre Situation. Unser Team bearbeitet Kundenanfragen zügig, daher werden wir direkt nach Eingang Ihrer Mitteilung mit der Lösung beginnen.



Ebenso können Sie Ihre Anliegen oder Anmerkungen bequem über die Webseite suncemarinkovic.com übermitteln. Scannen Sie einfach den QR-Code für die Seite zur Entgegennahme von Kundenrückmeldungen. Ihre Meinungen sind uns wichtig, und wir sind hier, um zu helfen.



FENSTERSCHMIERUNG

Die Wartung muss regelmäßig einmal im Jahr durch einen Fachbetrieb erfolgen (Nachweis durch Rechnungskopien). Ihre Fenster und Fenstertüren sind mit hochwertigen Drehkipp-Beschlägen ausgestattet. Diese Teile sollten Sie regelmäßig auf Beschädigungen, Verformungen und festen Sitz prüfen, vor allem weil einige davon auch sicherheitsrelevante Eigenschaften besitzen.

Damit diese einwandfrei, bequem und sicher funktionieren, sollten nachstehende Wartungsarbeiten mindestens einmal jährlich durchgeführt werden.

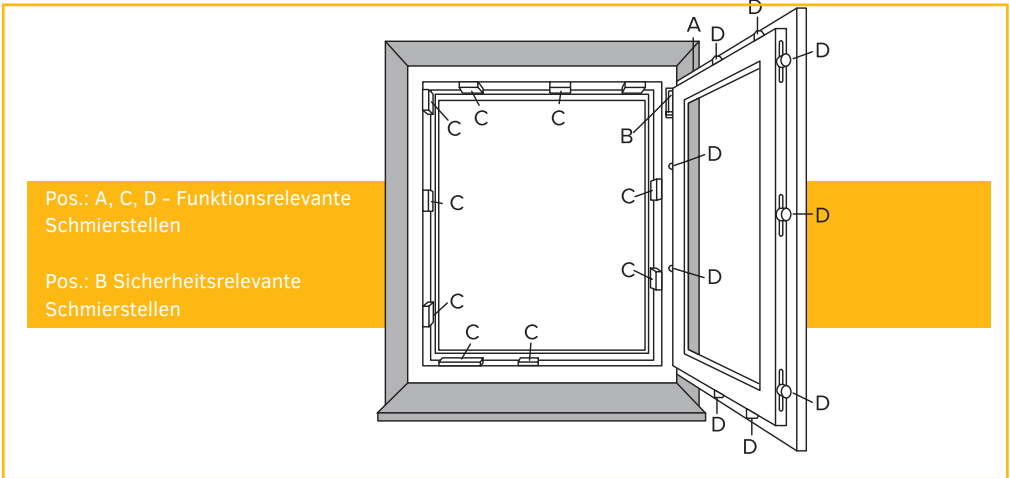

Das Bewegliche Teile, Verschlussstellen, Auflaufbock am Kippschließblech sollten geölt bzw. gefettet werden (hierzu handelsübliche Schmiermittel – z.B. Kriechöl - ohne Silikon verwenden). Bei der Behandlung der Oberflächen ist darauf zu achten, dass die Beschlagsteile nicht überstrichen werden. Die Beschläge der Fenster sollten so eingestellt sein, dass die Bedienung leichtgängig ist. Dies sollte von einem Fachmann erledigt werden.

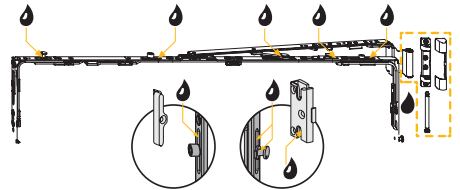

BEACHTEN Sie folgende Gefahrenquellen! (Fehlerhafte Produktnutzung)

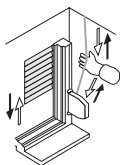

Führen Sie den Gurt ohne seitlichen Versatz nach unten oder oben. Betätigen Sie den Rollladen im ersten und im letzten Drittel der Öffnungs- oder Schließbewegung langsam bis zum Anschlag.



BEACHTEN Sie folgende Gefahrenquellen! (Fehlerhafte Produktnutzung)

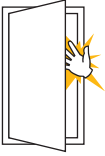

Vorsicht vor dem Einklemmen von Körperteilen im Öffnungsspalt zw. Flügel und Rahmen!



Vorsicht bei der Öffnungsstellung des Flügels. Verletzungsgefahr durch Windeinwirkung!

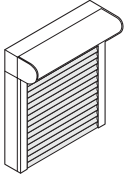

An sonnigen und heißen Tagen sollten Sie beachten, dass Licht- und Lüftungsschlitze geöffnet bleiben. Sie sorgen für eine ausreichende Hinterlüftung Ihres Rollladens und vermeiden einen Hitzestau, der dazu führen kann, dass der Rollladen verformt. An kalten und frostigen Tagen könnte Ihr Rollladen anfrieren. Bitte wenden Sie in diesem Fall keine Gewalt an. Lassen Sie speziell motorbediente Rollläden nicht unbeaufsichtigt laufen und stoppen Sie sofort, falls der Rollladen angefroren ist. Schalten Sie ggf. automatische Steuerungen und Zeitschaltuhren im Winter auf Handbedienung.

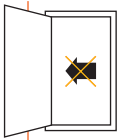

Andrücken des Flügels gegen Öffnungsrand (Mauerlaibung) unterlassen!

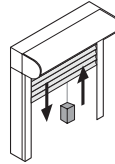

Nicht bestimmungsgemäße Verwendung Produkt nicht mit zusätzlichen Gewichten belasten.

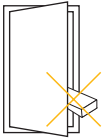

Einbringen von Gegenständen in den Öffnungsspalt zwischen Flügel und Rahmen unterlassen.

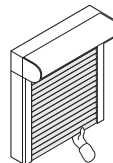

Falschbedienung Schieben Sie den Rollladen nie hoch. Dies könnte Funktionsstörungen hervorrufen.



Vorsicht bei Öffnungsstellung des Flügels. Absturzgefahr!



Zusatzbelastung des Flügels unterlassen!

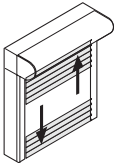

Beim Öffnen den Aufzugsgurt im letzten Drittel langsam betätigen. Rollladen soll nicht gewaltsam oben anschlagen. Beim Schließen den Aufzugsgurt im letzten Drittel langsam betätigen. Den Aufzugsgurt nie loslassen. **HINWEIS** Vermeiden Sie jede ruckartige Betätigung der Aufzuggurte.



Es besteht die Möglichkeit, dass Gegenstände aus dem Fenster fallen könnten, die Fußgänger verletzen könnten.

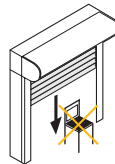

Verfahrbereich des Rollladens Das Abfahren des Rollladens darf nicht behindert werden. Hinweis: Achten Sie darauf, dass keine Hindernisse den Laufbereich des Rollladens versperren.



SEDIŠTE KOMPANIJE
I PROIZVODNJA
Braće Nikolić bb.
34000 Kragujevac, Srbija
+381 34 330 870
Viber +381 600 330 860
office@suncemarinkovic.com

Predstavništvo u Beogradu
SavAda 3 Tošin bunar 181b
11070 Novi Beograd
+381 11 6300 541
beograd@suncemarinkovic.com

Predstavništvo u Jagodini
Čočetova B5 - L2
35 000 Jagodina
+381 35 240 050
+381 65 330 8705
jagodina@suncemarinkovic.com

Predstavništvo u Aranđelovcu
Kralja Petra BB 34 300 Aranđelovac
+381 34 617 0607
+381 65 330 8750
arandjelovac@suncemarinkovic.com

Predstavništvo u Požarevcu
Kosovska 67 12 000 Požarevac
+381 12 531 121
+381 65 330 8764
pozarevac@suncemarinkovic.com